

添付1-1 System-A,Bの溶接情報記入方法の違い

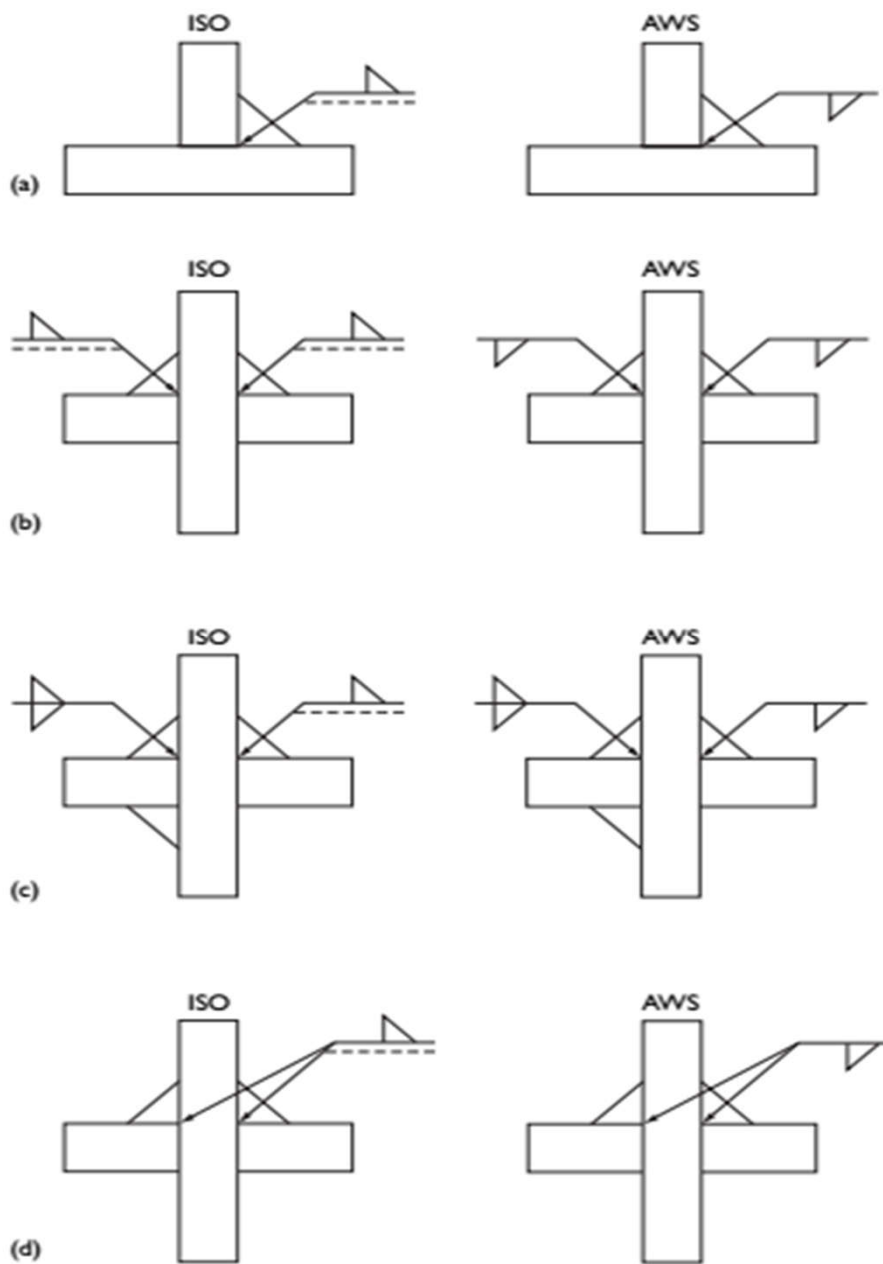

添付1-2 System-A,Bの溶接情報記入方法の違い

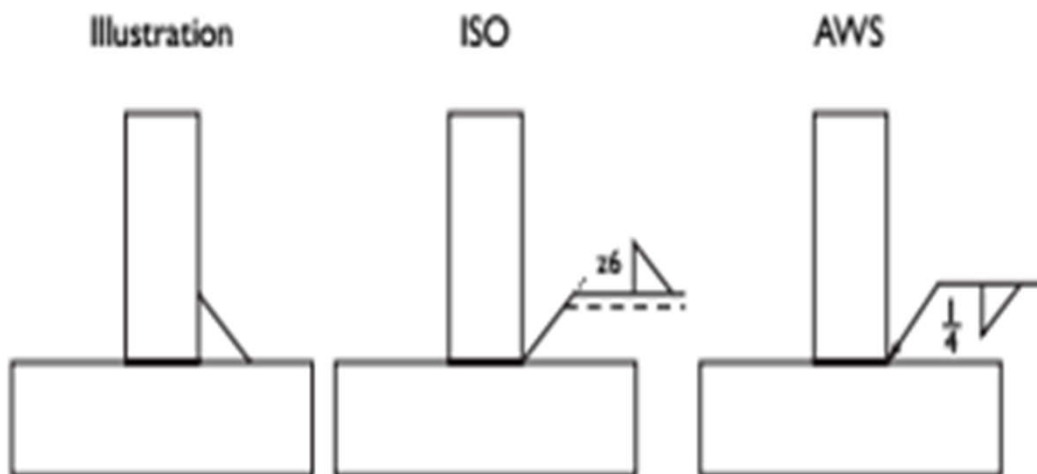

添付2-1 System-A,Bの脚長記載方法の違い

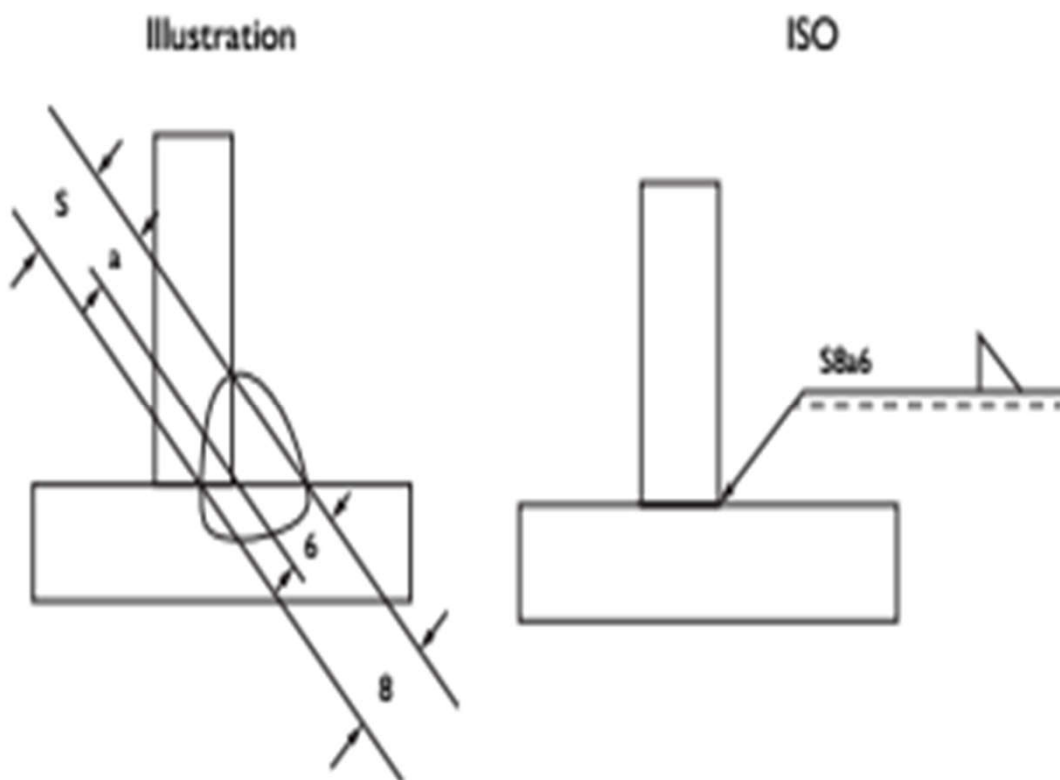

添付2-2 のど厚記載方法 (System-Aのみ)

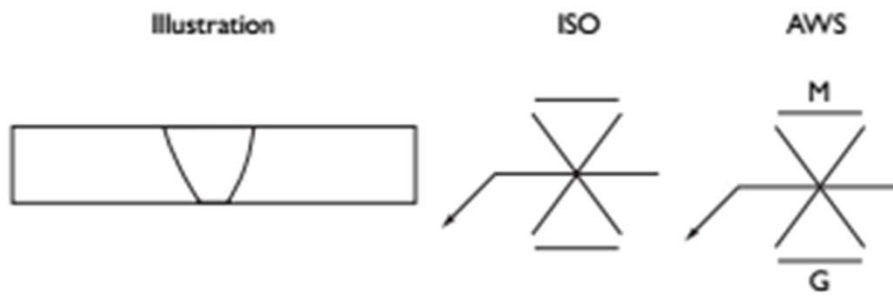



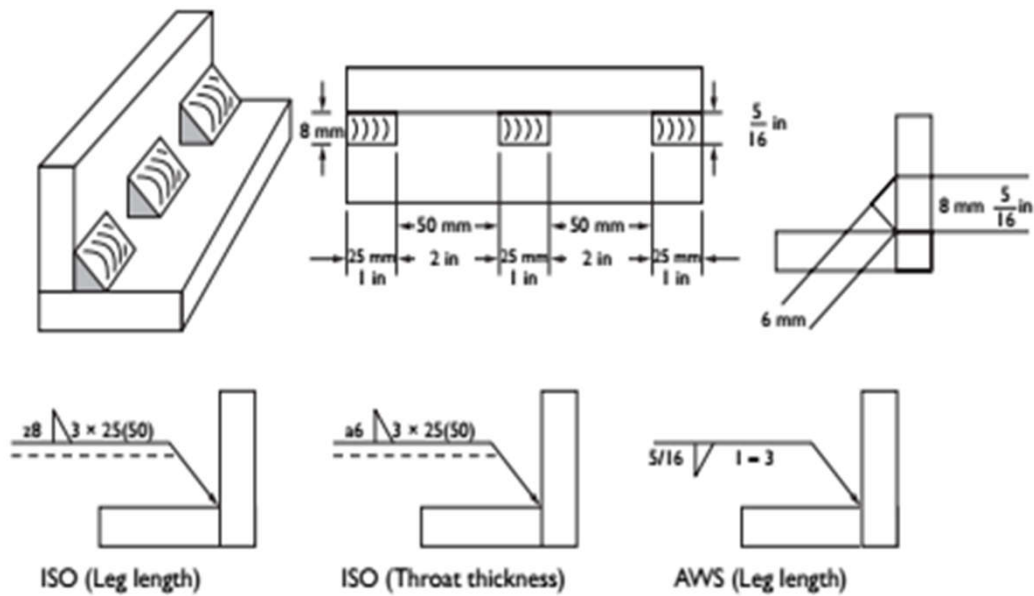





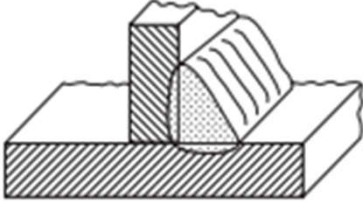

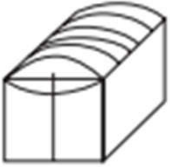

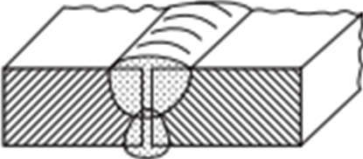
添付3 仕上げ方法の各記載方法

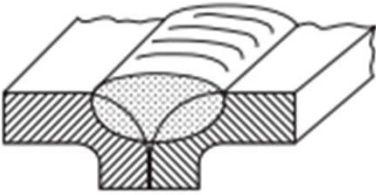

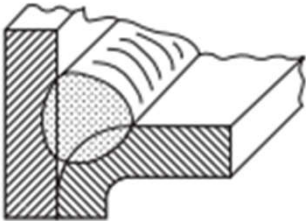
ISO (mm)	AWS (in)
z8 – leg length	5/16 – leg length
25 – length of each weld	1 – length of each weld
(50) – distance between the ends of adjacent welds	3 – pitch (centre to centre spacing)
3 – number of separate welds	

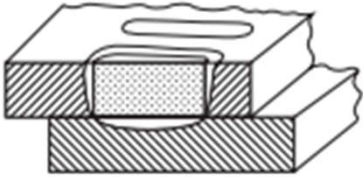













添付4 千鳥溶接の各記載方法

	Designation	Illustration	Symbol
(a)	Fillet weld		
(b)	Edge weld		
(c)	Backing run (ISO) Back or backing weld (AWS)		
(d)	Flare-V-groove weld (AWS)		
(e)	Flare-bevel-groove weld (AWS)		
(f)	Plug or slot weld		

添付5-1 System-A,Bの各溶接記号の比較①

	Designation	Illustration	Symbol
(a)	Single-V butt/groove weld		
(b)	Square butt/groove weld		
(c)	Single bevel butt/groove weld		
(d)	Single-U butt/groove weld		
(e)	Single-J butt/groove weld		
(f)	Butt weld between plates with raised edges (ISO) Edge weld on a flanged groove joint (AWS)		 ISO AWS
(g)	Single-V butt weld with broad root face		
(h)	Single bevel butt weld with broad root face		

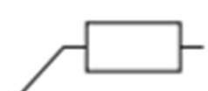
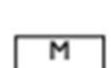
添付5-2 System-A,Bの各溶接記号の比較②

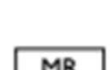
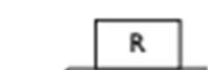
ISO	AWS	ISO	AWS
 Flat (usually finished flush)	 Flush or flat	No symbol	 Melt through
 Convex		No symbol	 Consumable insert
 Concave		 Peripheral weld	 Weld all round
 Toes shall be blended smoothly	No symbol	 Field or site weld	 Field weld
No symbol	 Spacer	 Permanent backing strip used	 Backing
No symbol	 Back or backing weld	 Removable backing strip used	 Removable backing

添付5-2 System-A,Bの各補助記号の比較